

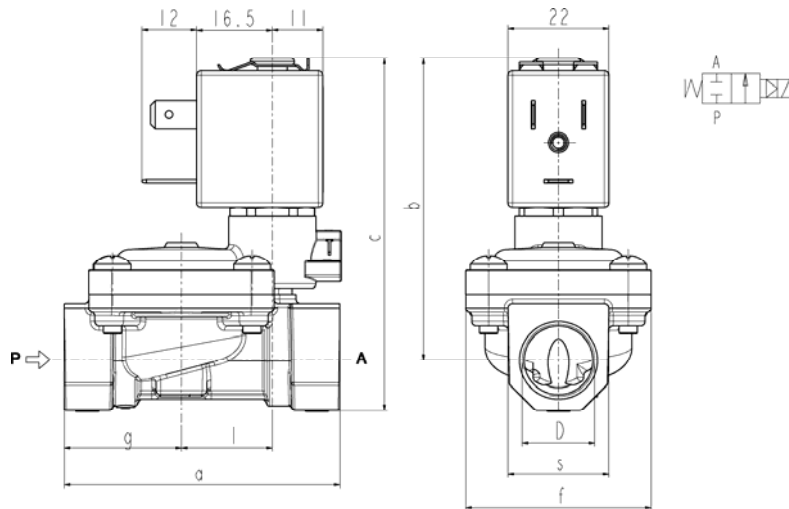

SOLENOID VALVE
2/2- NC (Normally closed)
Pilot operated
G 3/8 ÷ G 1

L182



D	a	b	c	f	g	l	s
G 3/8	60	66	77	40	25,5	20	22
G 1/2	66	68	82	40	29	20	27
G 3/4	79	72,5	89	50	35,5	24,5	33
G 1	105	85	106	71	46	28	42

► GENERAL FEATURES

Diaphragm valve, pilot operated, having full orifice.
 Suitable to shut off liquid and gaseous fluids (verify the compatibility of fluid with material in contact).

► TECHNICAL FEATURES

Maximum allowable pressure (PS) 20bar
Opening time from ~300ms to ~1500ms
Closing time from ~1000ms to ~2000ms
Fluid temperature -10°C +90°C (NBR)
 0°C +130°C (FPM)
 -10°C +140°C (EPDM)
Max viscosity 5°E (~37 cStokes o mm²/s)

► MATERIALS IN CONTACT WITH FLUID

Body Brass
Sealing NBR or FPM or EPDM
Internal components Brass and stainless steel
Seat Brass
Core tube Stainless steel
Shading coil Copper

► COIL

According to standards
Encapsulation material

Insulation class
Ambient temperature

Continuous duty
Electric connection

Protection degree

Voltages DC
 AC

*** On request**

According to standards
Voltages AC

ZB10A	ZB12A *	ZB14A *
/	UL and CSA	UL and CSA
PA fiberglass reinforced	PET fiberglass reinforced	PET fiberglass reinforced
F (155°C) -10°C +60°C	F (155°C) -10°C +60°C	H (180°C) -10°C +75°C
ED 100%		
DIN 46340- 3 poles plug connector		
IP 65 (EN 60529) with plug connector	IP 67 (EN 60529) with plug connector	IP 67 (EN 60529) with plug connector
12-24V (+10% -5%)		
24V/50-60Hz - 115V/50Hz - 230V/50-60Hz (+10% -15%)		
(Other voltages and frequencies on request).		
/	ZB12Y	ZB14Y
/	UL	UL
/	220-230V/50Hz	208-240V/60Hz

Port size ISO 228	Orifice size (mm)	Differential pressure (bar)						Kv (m ³ /h)	Series and type			Power absorption				Sealings	Notes	Weight (kg)
		Δp min	Δp max				Valve		Valve with manual override	Coil	AC (VA)			DC				
			Gases		Liquids						Inrush VA	Holding VA	W		W			
			AC	DC	AC	DC												
3/8	13,5	0,35	16	16	16	16	2,5	L182(*)01	L182(*)02	ZB10A ZB12A	12	6	4	5,5	(*) = B (NBR) (*) = V (FPM) (*) = D (EPDM)	1	0,32	
1/2			16	16	16	16											3,8	0,38
3/4	12		12	12	12	5											0,52	
1	12		12	12	12	12											1,08	

► NOTES

- Sealings: B(NBR)=Nitrile-butylene elastomer V(FPM)=Fluoro-carbon elastomer D(EPDM)=Ethylene-propylene elastomer (WRAS/KTW homologated compound)
- Operation with gaseous media, at high pressure without any outlet restriction, can reduce the diaphragm life.
- On request coil in class H (ZB14A – see § “COIL”)
- The bracketed values of Δp max are related to valves with V(FPM) seals.
- 1 - Low power consumption coil on request (3,5 VA in AC – 3W in DC): Δp max = 12 bar
- 2 - Low power consumption coil on request (3,5 VA in AC – 3W in DC): Δp max = 8 bar

L182

► SPARE PARTS

L182 B-V-D01

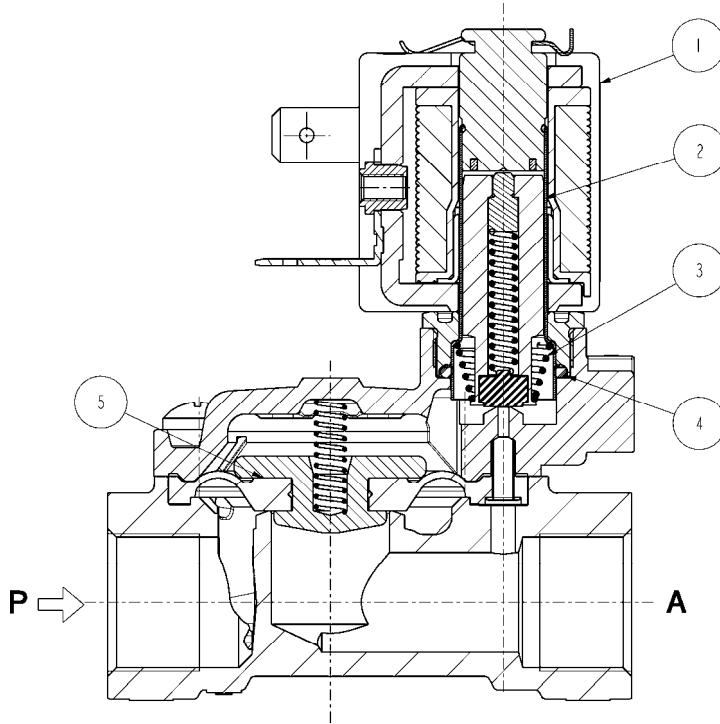

L182 B-V-D02

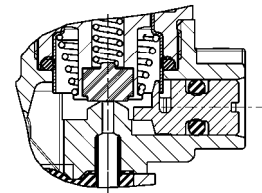

Kit description

Kit P.N.

Consisting of:

Core kit	L182B-V		G3138201	Core kit pos.2 Core return spring pos. 3 O-Ring guide assembly pos. 4
	L182D		G3138202	
Diaphragm assembly	L182B	3/8-1/2	2844302R	Diaphragm assembly pos.5
	L182V	3/8-1/2	2844303R	
	L182D	3/8-1/2	2844306R	
	L182B	3/4	2299701R	
		1	2380101R	
	L182V	3/4	2299702R	
		1	2380102R	
	L182D	3/4	2299708R	
		1	2380106R	
Coil			ZB10	Coil pos.1
			ZB12	
			ZB14	

► INSTALLATION

- Solenoid valve can be mounted in any position; vertical with coil upwards preferred.